

L&C Enterprises-USA
6652 N.75 Drive
Escanaba, MI 49829
(800) 786-1009
www.lcenterprises-usa.com



Check out a full list of our products by scanning this QR code with your phone or go to <https://www.lcenterprises-usa.com/products/>

THANK YOU FOR YOUR PURCHASE!



EXTREME LOBO POST PULLER

OWNER'S MANUAL



Proudly made in the Upper Peninsula of Michigan

 **L&C Enterprises-USA**
Fencing Products to Get the Job Done Fast

LOBO POST PULLER TABLE OF CONTENTS

DESCRIPTION	PAGE
WARRANTY	
Exclusion of Warranties	1
INTRODUCTION	
General Description	2
Features and Advantages	2
SAFETY	
Hydraulic Safety	3
Operating Safety	4
Safety Decal Location	5
OPERATION	
Pulling Operation	6
Changing Clamps	7-8
SERVICE AND MAINTENANCE	
Parts List	9
Model Parts Breakdown	10-11-13
Hydraulic Parts List	12

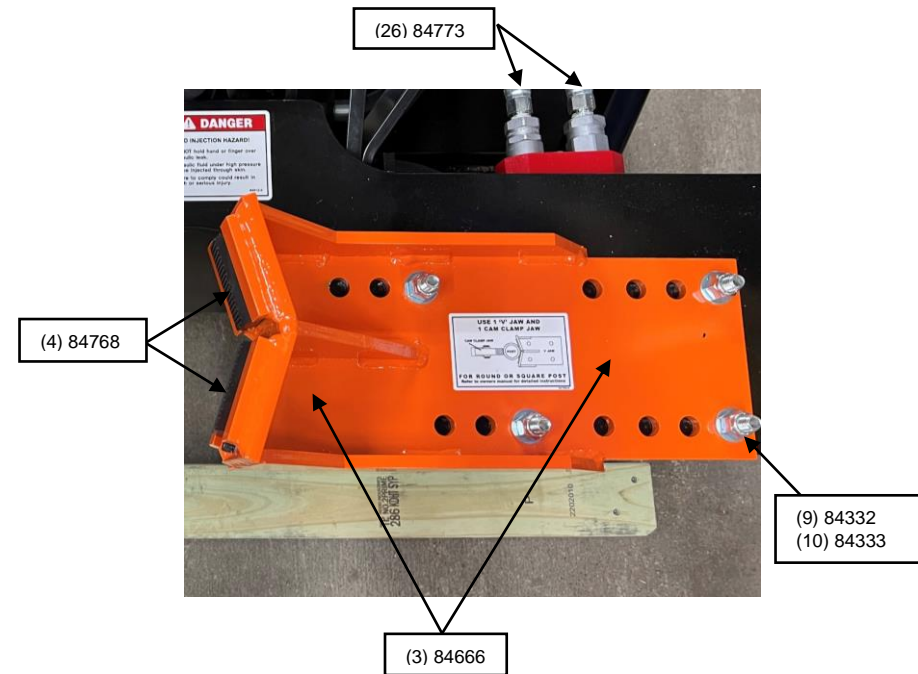
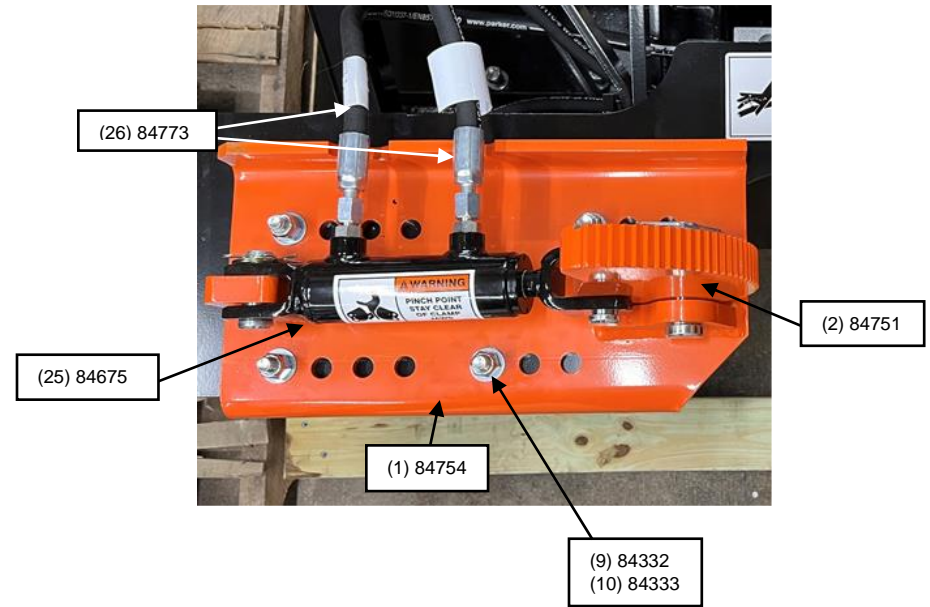

L&C Enterprises-USA
6652 N.75 Drive
Escanaba, MI 49829
(800) 786-1009
www.lcenterprises-usa.com
sales@lcenterprises-usa.com

HYDRAULIC PARTS

F/N HYDRAULIC ASSEMBLY KIT

Part No.	Qty.	Part	Description
84773-1	1	Hose Assy.	Left side clamp Cyl. retract (Female QD included on hose)
84773-2	1	Hose Assy.	Left side clamp Cyl. extend (Male QD Included on hose)
84773-3	1	Hose Assy.	Right side pull Cyl. extend
84773-4	1	Hose Assy.	Left side pull Cyl extend
84773-5	2	Hose Assy.	Left and Right side clamp Cyl. retract
84773-6	2	Hose Assy.	Left and Right side pull Cyl.
84773-7	2	Hose Assy.	Loader connection (QD sold separately)
84773-8	1	QD	Male quick disconnect attached to Aux . Cyl.
84773-9	1	QD	Female quick disconnect attached to Aux. Cyl.

F/N 34 & 35 HYDRAULIC QUICK DISCONNECTS

84417	1	QD	Quick disconnect - female end
84418	1	QD	Quick disconnect - male end

F/N 30 MANIFOLD

84934	1	Manifold	Flow divider manifold block
-------	---	----------	-----------------------------

LOBO WARRANTY

L&C Enterprises, Inc. warrants each new product to be free from defects in material and workmanship.

For 90 days from the date of purchase, when the attachment has been maintained and lubricated in accordance with the operating and maintenance instructions in the Owner's Manual, L&C Enterprises will replace free of charge, any defect in material or workmanship in this product.

This warranty does not cover:

This warranty excludes cam clamps and replaceable jaws on the V-brace, which are expendable and become worn during normal use.

Repairs on the LOBO POST PULLER because of alteration, an accident, or operator abuse or negligence, including the failure to maintain and operate the equipment according to instructions contained in the Owner's Manual, or if repairs have been made with parts other than those obtainable through L&C Enterprises, Inc.

Our obligation under this warranty shall be limited to repairing and replacing, free of charge to the original purchaser, any part that in our judgement shows evidence of a defect, provided the part is routed through the dealer and distributor from whom the purchase was made, transportation charges prepaid.

This warranty shall not be interpreted to render us liable for injury or damages of any kind. This warranty does not extend to any expense or loss incurred for labor, supplies, substitute machinery rental, or any other reason.

This warranty is subject to any existing condition of supply which may directly affect our ability to obtain materials or manufacture replacement parts.

L&C Enterprises, Inc. reserves the right to make improvements in design or changes in specifications at any time, without incurring any obligations to owners of units previously sold.

No one is authorized to alter, modify, or enlarge this warranty nor the exclusions, limitations and reservations.

Every L&C Enterprises product is the highest quality. If you wish to contact us regarding this product, please call 906-786-1008

INTRODUCTION

GENERAL DESCRIPTION

The LOBO post puller attachment will remove a fence post or guardrail from the ground in one step, making it a one person job. This machine will pull round fence posts and also many shapes and sizes including T-posts and I-Beam guardrails. Take time to review and familiarize yourself with this Owner's Manual paying special attention to the safety and the operation sections.

1. Post Clamp Jaws
 - a. Post clamp jaw assemblies are adjustable to pull post sizes 1" thru 7" in diameter.
 - b. Virtually any shape, round, square, T-posts, H post, can be clamped and pulled.
 - c. Able to grip and pull wood or steel posts.
 - d. Clamp jaws are made from hardened steel, and will pull many posts before requiring replacement parts.
 - e. Jaws are easily replaced. No tools required.
2. Post puller is quickly and easily connected to a skid steer, or other similar machinery. Mechanical and hydraulic hookup are quick and easy for any skid steer.
3. Post is loaded into the puller from the front, (as opposed to loading the machine over the top of the post). Posts can be removed and replaced while leaving an existing fence intact.
4. Post puller rests on the ground, requiring no lifting of post/ concrete until post is completely broken free from the ground.
5. Machine is designed for minimum depth so it takes up less "Lane Space" when working on Highway jobs.
6. Post can be removed by one person.
7. Breakout pulling force of 27,000 lbs.

NOTE: POST PUSH BAR NOT COMPLETELY SHOWN FOR CLARITY

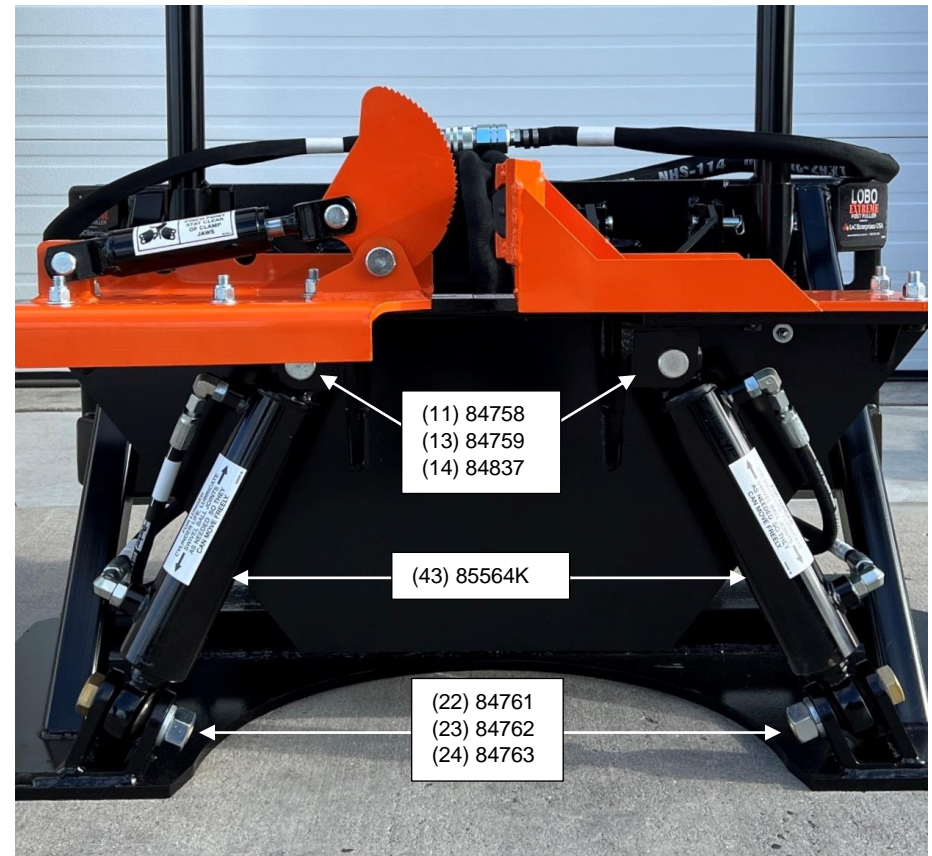

NOTE: POST PUSH BAR NOT COMPLETELY SHOWN FOR CLARITY

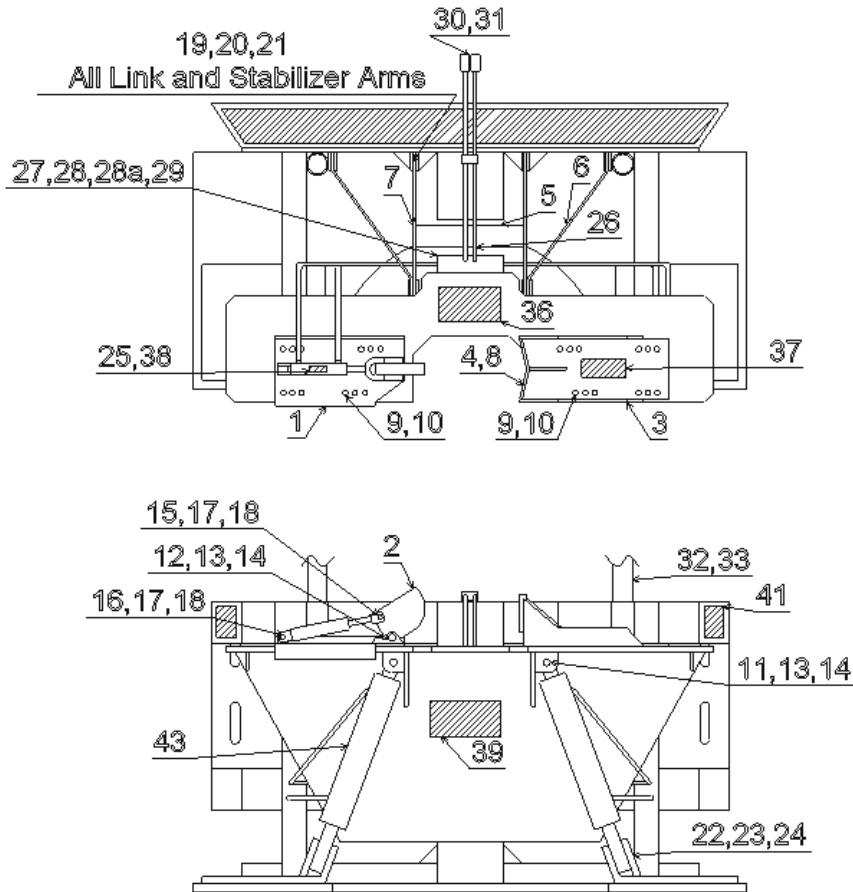

HYDRAULIC SAFETY

1. Always place hydraulic controls in neutral before dismounting your loader.
2. Make sure that all components in the hydraulic system are kept in good condition and are clean.
3. Replace any worn, cut, abraded, flattened, or crimped hoses and fittings.
4. Place hydraulic controls in neutral, and wait for all moving parts to stop before servicing, adjusting, repairing or unplugging. **Cycle machine completely to the unclamped/down position before attempting servicing.**
5. Do not attempt any makeshift repairs of the hydraulic lines, fittings or hoses by use of tape, clamps or cement. The hydraulic system operates under extreme high-pressure. Such repairs may fail suddenly and create a hazardous and unsafe condition.
6. Before applying pressure to the system, make sure all components are tight and that lines, hoses, and quick couplings are properly connected.
7. Wear proper hand and eye protection when searching for a hydraulic leak. Use a piece of wood or cardboard as a backstop instead of hands to find a leak. Hydraulic fluid escaping under pressure can have sufficient force to penetrate skin and cause serious injury, and if fluid is injected into the skin it must be surgically removed within a few hours by a doctor familiar with this form of injury or gangrene may result.

	⚠ DANGER
	<p>FLUID INJECTION HAZARD!</p> <p>DO NOT hold hand or finger over hydraulic leak.</p> <p>Hydraulic fluid under high pressure will be injected through skin.</p> <p>Failure to comply could result in death or serious injury.</p> <p style="text-align: right; font-size: small;">84912-5</p>

SAFETY

OPERATING SAFETY

1. Read and understand the Owner's Manual and all safety decals before connecting, disconnecting, adjusting or operating this machine.
2. Do not allow riders on this attachment during operation or transport.
3. Keep hand, feet, hair, and clothing away from all moving and clamping parts.
4. Place hydraulic and skid steer controls in neutral, and wait for all moving parts to stop before servicing, adjusting, repairing or unplugging. Cycle machine completely to the unclamped/down position before attempting servicing.
5. Use caution when stepping over hydraulic hoses upon entering and exiting machine.
6. When operating this machine, insure that you are at least 25 ft. from the nearest bystander, especially children.
7. When releasing a post from the gripping jaws, be careful. The post-concrete will fall to the ground which could result in injury to bystanders.
8. Stay away from overhead obstructions and power lines during setup and operation. Electrocution can occur even without direct contact.
9. Ensure that Post Push Bar is installed prior to pulling a post or any object that could fall into the cab. The post push bar also can be used as a hand hold for safer entry and exit from the loader.
10. Review all safety instructions annually.
11. Do not attempt to remove any type of telephone/utility poles with this machine. Due to the height and weight of these type of poles, it may cause an unstable and unsafe conditions for the operators or bystanders.



Remember, YOU are the key to safety. good safety practices not only protect you but also the people around you from injury or death.

PARTS LIST (STANDARD)

F/N	P/N	QUANTITY	DESCRIPTION
1.	84754	1	Cylinder Plate Weldment (RH)
2.	84751	1	Long Throw Jaw
3.	84666	1	V-Jaw Brace Weldment
4.	84768	2	Small Replaceable Jaws
5.	84802	1	Link Arm Weldment (Lower Assembly- Not Shown)
6.	84803	4	Link Arm Stabilizer (Upper Assembly)
7.	84642	2	Link Arm (Upper Assembly)
8.	84772	2	Socket HD Cap Screw 1/4"-20x3/4" long
9.	84332	10	1/2" - Lock Nut
10.	84333	10	1/2" - Lock Washer
11.	84758	2	1" dia. 3-1/2" Long Clevis Pin - Large Cylinder
12.	84755	1	1" dia x 3" Long Clevis Pin -Small Cylinder
13.	84759	3	1" Flat Washer
14.	84837	3	1" Rue Ring Cotter Pin
15.	84757	1	3/4" dia. x 2-1/2" Long Clevis Pin
16.	84756	1	3/4" dia x 2" Long Clevis Pin
17.	84671	2	3/4" Flat Washer
18.	84836	2	3/4" Rue Ring Cotter Pin
19.	84838	12	5/8" dia. x 2-1/4" Long Clevis Pin
20.	84839	12	5/8" dia. x 18 ga Flat Washer (discontinued)
21.	84840	12	5/8" Rue Ring Cotter Pin
22.	84761	2	1" - 14 UNF x 4" Long Hex HD Bolt
23.	84762	2	1" - 14 UNF Nut
24.	84763	2	1" dia. Lock Washer
25.	84675	1	Clamp Cylinder
26.	84773	1	Hydraulic Hose Assy. (See p. 12 for breakdown)
27.	84934	1	Flow Divider Return Manifold
28a.	84155	3	1/4" x20x4" Hex Head Bolt
28.	84515	3	1/4" Locknut
29.	84752	3	1/4" Washer
30.	84417	1	Q.D. Coupler Male
31.	84418	1	Q.D. Coupler Female
32.	84753	1	Safety bar
33.	84778	2	Snap Pin
34.	84769	1	Decal Kit
35.	84769-1	1	Pulling H-Post Decal (Decal Kit)
36.	84912-5	1	Fluid Injection Hazard (Decal Kit)
37.	84769-4	1	V-Jaw Decal (Decal Kit)
38.	84769-3	1	Cam Clamp Decal (Decal Kit)
39.	84912-7	1	Made in USA Decal (Decal Kit)
40.	84548	1	Lobo ID Tag
41.	85164	2	Lobo Decal
42.	84771	1	Non-skid Tape
43.	85564K	2	Heavy-duty Lift cyl. w/ adapters
44.	84665	-	Cylinder Plate Weldment (LH) (Optional – H-Post Attachment)

PARTS LIST (OPTIONAL H-POST ATTACHMENT)

F/N	P/N	QUANTITY	DESCRIPTION
2.	84751	1	Long Throw Jaw
12.	84755	1	1" dia x 3" Long Clevis Pin -Small Cylinder
13.	84759	1	1" Flat Washer
14.	84837	1	1" Rue Ring Cotter Pin
15.	84757	1	3/4" dia. x 2-1/2" Long Clevis Pin
16.	84756	1	3/4" dia x 2" Long Clevis Pin
17.	84671	2	3/4" Flat Washer
18.	84836	2	3/4" Rue Ring Cotter Pin
25.	84675	1	Clamp Cylinder
35.	84769-1	1	Pulling H-Post Decal (Decal Kit)
44.	84665	1	Cylinder Plate Weldment (LH)

Directions for changing cam clamps to a V-Jaw with throw.

FOR USE WITH A ROUND OR SQUARE POST

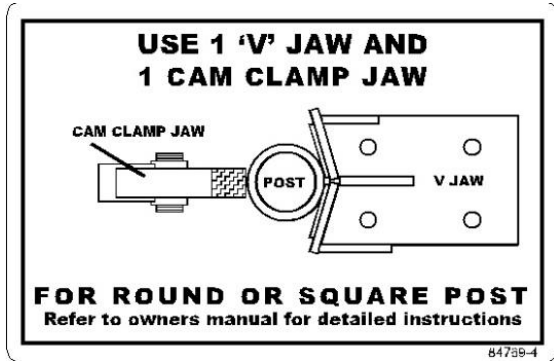

1. IMPORTANT:

Follow all hydraulic and machine safety procedures listed above in the Operating and Safety section of your LOBO Owner's Manual.

2. Unhook hydraulic hoses attached to the left hand cylinder. Place hydraulic hoses in the hose storage brackets.

3. Remove brace weldment from storage bracket located on the bottom of the unit.

4. Unscrew nuts on the left hand cylinder plate. Remove the cylinder plate and attach it to the storage bracket located on the bottom of the unit.

5. Align the brace weldment and reattach nuts.

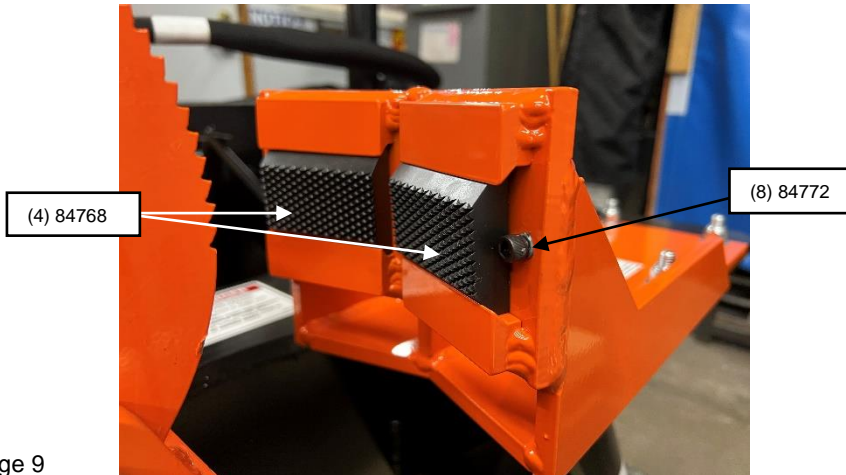

SAFETY DECALS AND DECAL LOCATION

The types of decals and locations on the equipment are shown in the illustration below. Good Safety requires that you familiarize yourself with the various Safety Decals, the type of warning and the area, or particular function related to that area. If Safety Decals have been damaged, removed, become illegible or parts replaced without decals, new decals must be applied. New decals are available from you authorized dealer or from L&C ENTERPRISES, INC.

1. Keep safety decals and signs clean and legible at all times.
2. Replace safety decals and signs that are missing or have become illegible.

DECALS INCLUDED IN 84769 DECAL KIT

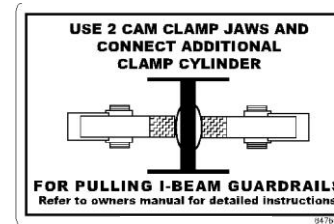

(37) 84769-1

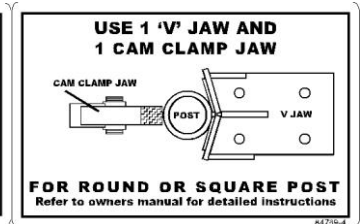

(38) 84769-3



(37) 84769-4

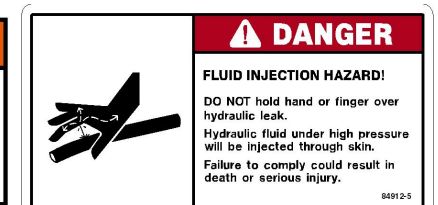

(36) 84912-5



(39) 84912-7



(41) 85164

OPERATION

The method of operation is as follows:

Hookup - Please read your skid steer Owner's Manual. The hookup procedure is the same as other powered attachments for your skid steer loader.



1. **IMPORTANT:** Adjust cylinder plate weldment & V-jaw brace weldment in as far as possible, while still allowing space to maneuver post puller around post to be pulled. Failure to do so can over-extend clamp cylinder and damage machine.
2. Drive up to the post, aligning post gripping jaw and V-clamp with the post.



3. **IMPORTANT:** Use extreme caution not to set unit on bystanders foot. Set machine base flat on the ground by lowering the skid steer loader arms and using the "bucket roll" function of the loader. The machine base must set on the ground to develop the required breakout force.
4. Activate the hydraulic auxiliary circuit. The post will be clamped and pulled from the ground in one easy operation.
5. Once broken loose from the ground, the puller and the post can be raised out of the hole by lifting the loader arms and carried to a desired location.
6. Post may be carried to the "drop" location, and released by activating the hydraulics to cause reverse flow, thus unclamping the post.



IMPORTANT: Make sure the area is clear when unclamping the post. A falling post may cause injury or death to a bystander or may cause unnecessary damage to other equipment.

SERVICE AND MAINTENANCE

Place hydraulic controls in neutral, and wait for all moving parts to stop before servicing, adjusting, repairing or unplugging.

Cycle machine completely to the unclamped/down position before attempting servicing. Hydraulic fluid escaping under pressure can have sufficient force to penetrate skin and cause serious injury, and if fluid is injected into the skin it must be surgically removed within a few hours by a doctor familiar with this form of injury or gangrene may result.

Metal burrs located on the cam clamps may inflict injury. Wear proper hand and eye protection when changing cam clamps or maintaining the unit.

LUBRICATION: Periodically remove pins and pivot bolts and apply a heavy grease such as Moly-Graph high pressure grease or equivalent to all points. This is especially important on the clamp jaws.

HYDRAULICS: Replace hoses that are showing wear. Replacement hydraulic hoses are available from L&C Enterprises, Inc. When changing hoses, make sure all components are tight and that lines, hoses, and quick couplings are properly connected before applying pressure to the system.

Directions for changing cam clamps to a V-jaw with SHORT THROW FOR PULLING I/H BEAM POSTS OR GUARDRAILS

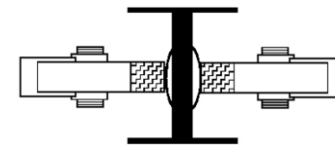

1. **IMPORTANT:** Follow all hydraulic and machine safety procedures listed above in the Operating and Safety section of your LOBO Owner's Manual.
2. Remove cylinder plate from storage bracket located on the bottom of the unit.
3. Unscrew nuts and remove the brace weldment. Attach it to the storage bracket located on the bottom of the unit.
4. Align the cylinder plate and reattach nuts.
5. Attach hydraulic hoses.